

ABBREVIATIONS

A	ABOVE FINISHED FLOOR	A.F.F.	ACT.	ALUMINUM ANOD.	ALUM.
B	BATT INSULATION	BATT INSUL.	BM.	BOTH WAYS	B.W.
C	CERAMIC TILE	C.C.	COL.	COMPLETE WITH CONCRETE	C.W.
D	CONCRETE BLOCK CONSTRUCTION	CONC. BL.	CONC.	CONCRETE CORNER	CONC. CORN.
E	ELECTRICAL	ELEC.	EQ.	EXISTING	EXIST.
F	FLOOR	F.L.	F.D.	FLOOR AREA RATIO	F.A.R.
G	GRADE	GR.	G.F.A.	GROSS FLOOR AREA	G.F.A.
H	HOLLOW METAL	H.M.	H.R.	HORIZONTAL	H.O.
I	INTERIOR	INT.	I.F.	INSIDE FACE	I.F.
J	JANITOR	JAN.	J.M.	MANHOLE	M.H.
L	LAMINATED	LAM.	L.V.	LESS THAN	L.T.
M	MASONRY	M.S.	M.C.	MAXIMUM	MAX.
N	NATURAL	NAT.	N.A.	NOT APPLICABLE	N.A.
O	OPENING	OPG.	O.D.	OUT TO OUT	O.T.O.
P	PLYWOOD	PLY.	P.C.	PREFINISHED	P.F.
Q	QUARRY TILE	Q.T.	R.	RADIUS	R.
R	REQUIRED	REQ.	R.F.	REFRIGERATOR	R.F.
S	SOLID CORE	S.C.	S.P.	SPECIFICATIONS	SPEC.
T	TOWEL DISPENSER	T.D.	T.S.	TONGUE AND GROOVE	T.&G.
U	UNDERSIDE	UIS.	U.L.C.	UNDERWRITERS LABORATORIES UNPROTECTED OPENING(S)	U.L.C.
V	VENEER	VEN.	V.C.T.	VINYL COMPOSITE TILE	V.C.T.
W	WAREHOUSE	W.H.	W.C.	WATER CLOSET	W.C.

DRAWING REFERENCE SYMBOLS

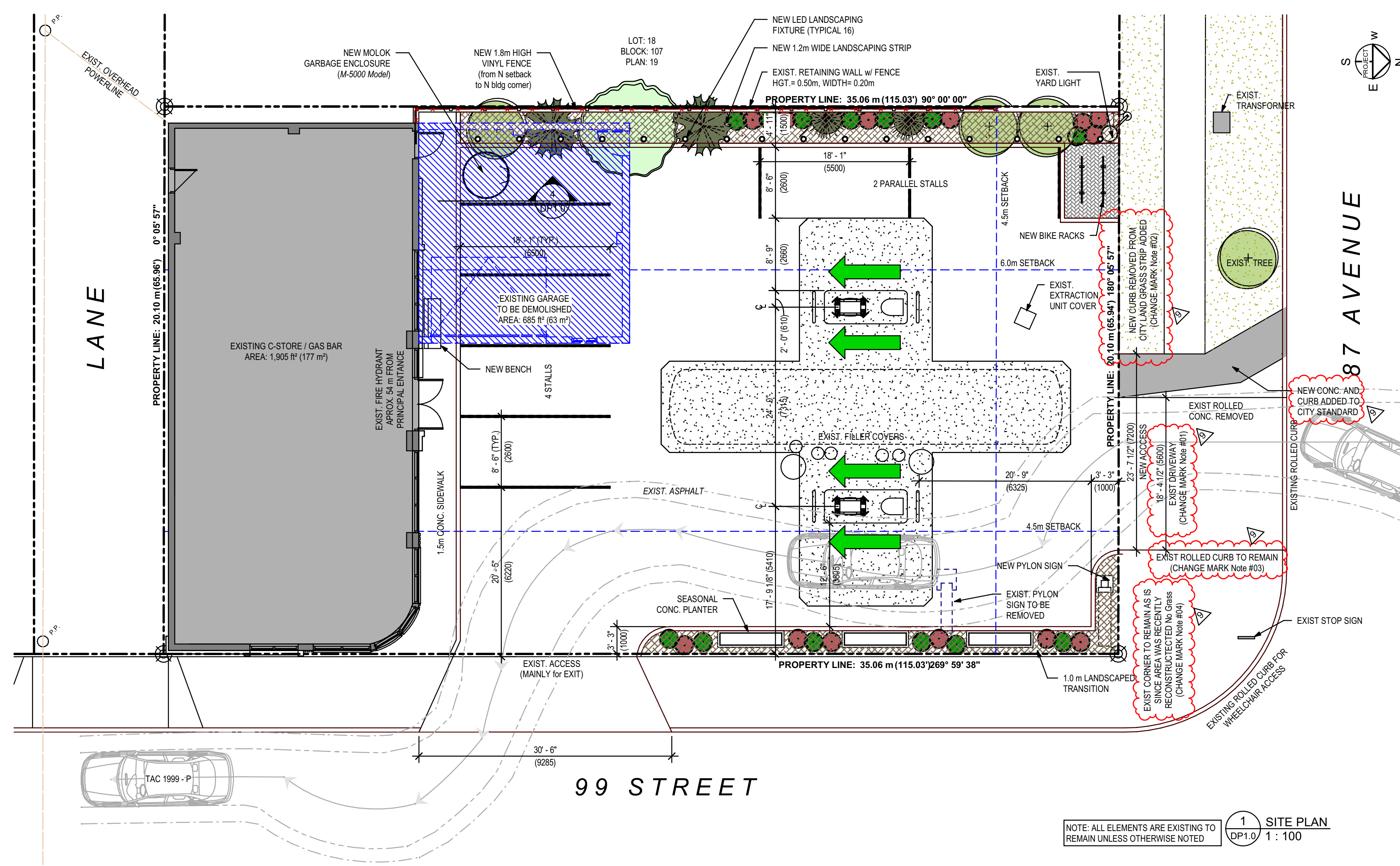
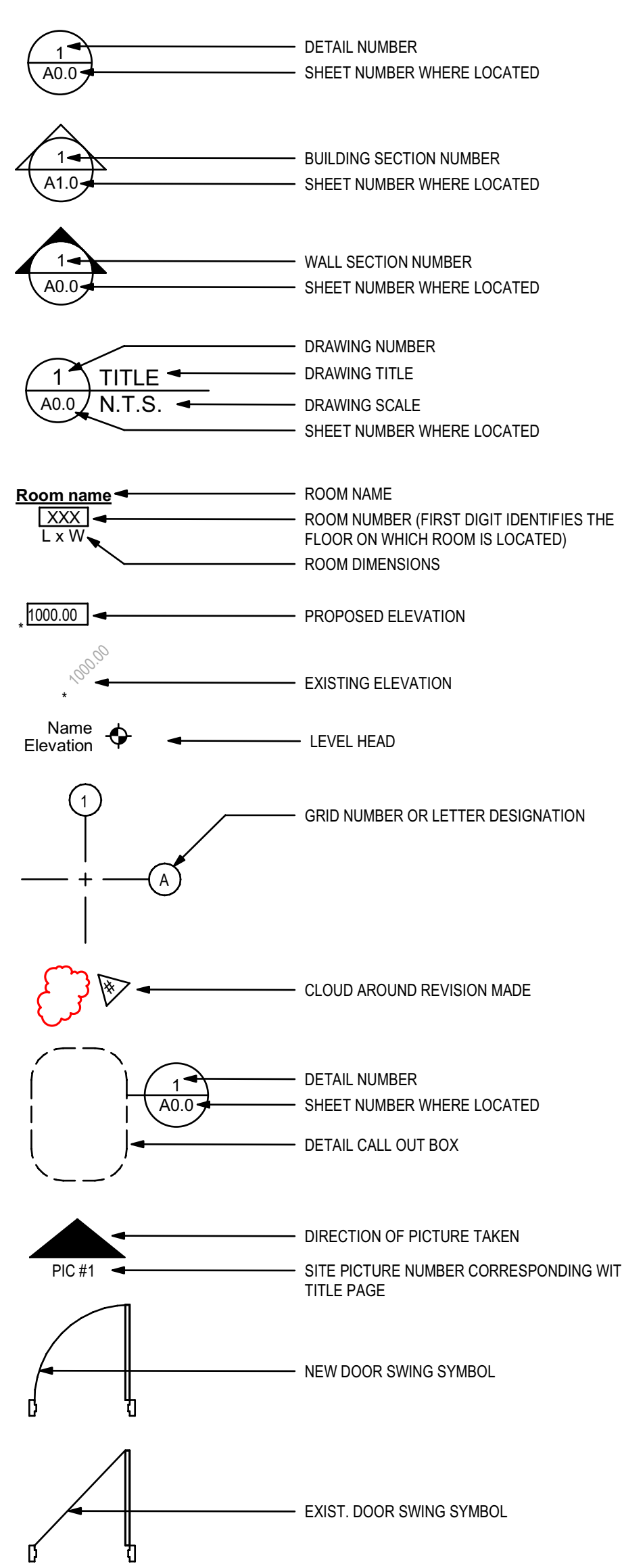

GENERAL NOTES

METRIC :
ALL DIMENSIONS ARE IN METRES AND MILLIMETRES UNLESS OTHERWISE NOTED. IMPERIAL IN BRACKETS.

SITE INFORMATION
TOTAL LOT AREA: ± 0.17 acres (0.07 ha) 690 m²
ZONING: BYLAW 12800 (CNC) NEIGHBOURHOOD CONVENIENCE COMMERCIAL ZONE
USE: CONVENIENCE RETAIL STORE / GAS BAR

EXISTING BUILDING AREA:
C-STORE / GAS BAR 1,905 ft² (177 m²)
GARAGE 685 ft² (63 m²)
EXISTING BUILDING AREA: 2,590 ft² (240 m²)
DEMOLISHED AREA: 685 ft² (63 m²)
TOTAL BUILDING AREA: 1,905 ft² (177 m²)

PARCEL COVERAGE:
BUILDING FOOTPRINT = 177 m² (1,905 ft²)
LOT AREA = 690 m²
177 m² / 690 m² = 25.7% PARCEL COVERAGE
FAR: 177 m² (G.F.A.) / 690 m² (LOT AREA) = 0.257

PARKING:
CONVENIENCE RETAIL STORE / GAS BAR:
= 1 STALLS / 40 m² GROSS FLOOR AREA = 177 m² / 40 m² = 4.4
TOTAL PARKING REQUIRED: 4.4 = 5 STALLS
TOTAL PARKING PROVIDED: 6 STALLS

BICYCLE PARKING:
NOTE: BICYCLE PARKING IS EXISTING WITH ADDITION OF 2 NEW BIKE RACKS

WALL LEGEND
EXISTING WALL TO REMAIN
NEW WALL TO BE CONSTRUCTED
DEMOLISHED WALL TO BE REMOVED

TAC 1999 - P
N.T.S. METERS
WIDTH : 2.00
TRACK : 2.00
LOCK TO LOCK TIME : 6.00
STEERING ANGLE : 35.9

COM-TECH Drafting and Design Services
306B 1235 25th Avenue SE phone: 403.283.3040
Calgary, AB T2G 1R7 fax: 403.282.0399
www.comtechdesign.com

CLIENT: CENTEX PETROLEUM
CONTACT PERSON: AKBAR LAIWALLA
PROJECT: 99 STREET, EDMONTON CENTEX
MUNICIPAL ADDRESS: 8616 - 99th STREET NW EDMONTON, ALBERTA
LEGAL ADDRESS: LOT: 16-17 BLOCK: 107 PLAN: 19
DRAWING: SITE PLAN & SITE INFORMATION
DRAWN BY: JLC
DATE: 13 SEP 19
SCALE: As indicated
CHECKED BY: DP1.0

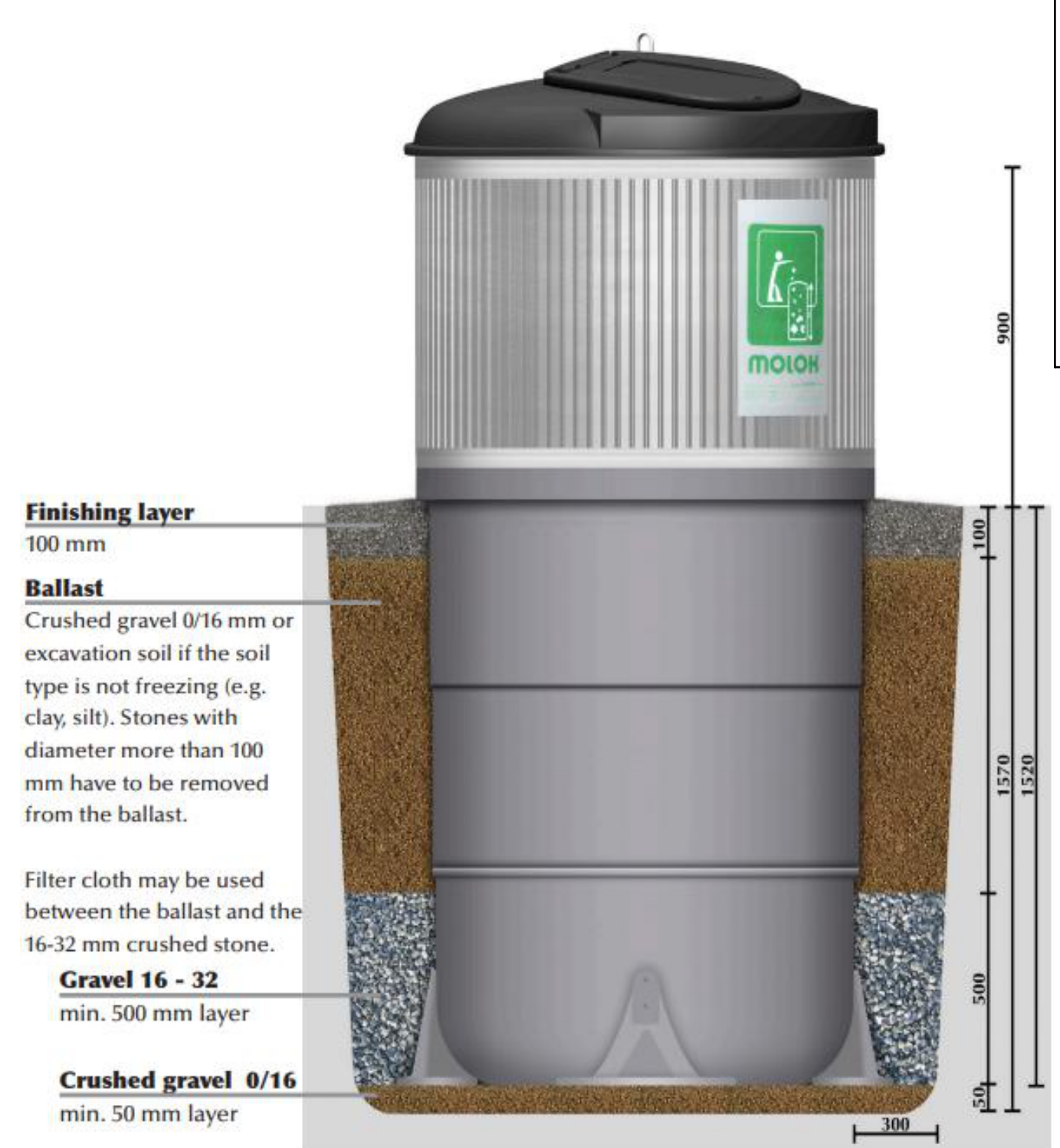

PLANTING LEGEND

REQD	QTY.	TYPE	SIZE/HGT.	SPECIES
7	13	CONIFEROUS SHRUB	450 mm SPREAD	'MOPS' MUGO PINE (Pinus Mugo 'Mops')
2	2	CONIFEROUS TREE LARGE	MIN. HGT. 3.5 m	COLUMNAR BLUE SPRUCE (Picea)
3	2	CONIFEROUS TREE SMALL	MIN. HGT. 2.5 m	BRANDON CEDAR (Thuja Occidentalis)
7	13	DECIDUOUS SHRUB	300 mm HGT.	BARBERRY (Berberis Vulgaris)
2	1	DECIDUOUS TREE LARGE	MIN. SIZE 70 mm CALIPER	DAKOTA PINNACLE BIRCH (Betula Platyphylla)
2	4	DECIDUOUS TREE SMALL	MIN. SIZE 50 mm CALIPER	DAKOTA PINNACLE BIRCH (Betula Platyphylla)

LANDSCAPING REQUIREMENTS
AREA REQUIRED: 210m² (6m WEST SIDE YARD SETBACK)

TREES & SHRUBS REQUIRED
= 1 TREE / 25 m² OF SETBACK AREA = 210 m² / 25 m² = 8.4 = 9 TREES
= 1 SHRUBS / 15 m² OF SETBACK AREA = 210 m² / 15 m² = 14 SHRUBS

(9 TREES REQUIRED - 4 DECIDUOUS, 5 CONIFEROUS)
- REQUIRED DECIDUOUS:CONIFEROUS RATIO = 50:50
- MIN. 50% DECIDUOUS TREES TO BE LARGE TREES
- MIN. 25% CONIFEROUS TREES TO BE LARGE TREES

NOTE:
- ALL LANDSCAPING SHOWN IS PROPOSED UNLESS OTHERWISE NOTED.
- LANDSCAPING TO BE WATERED BY LOW WATER IRRIGATION.
- ALL TREES/SHRUBS ARE LOW WATER REQUIRED.

LANDSCAPE LEGEND

PLANTING BED CONSTRUCTION (EXCAVATION TO 300mm DEPTH, INSTALL CLASS B TOPSOIL & 100mm MULCH) [QTY. = 39.6m ²]
STAMPED CONCRETE [QTY. = 5.5m ²]
BENCH [QTY. = 1]
LED LANDSCAPING FIXTURE [QTY. = 16]
SEASONAL CONCRETE PLANTER 96"x24"x24" [QTY. = 3]
BIKE RACK [QTY. = 2]

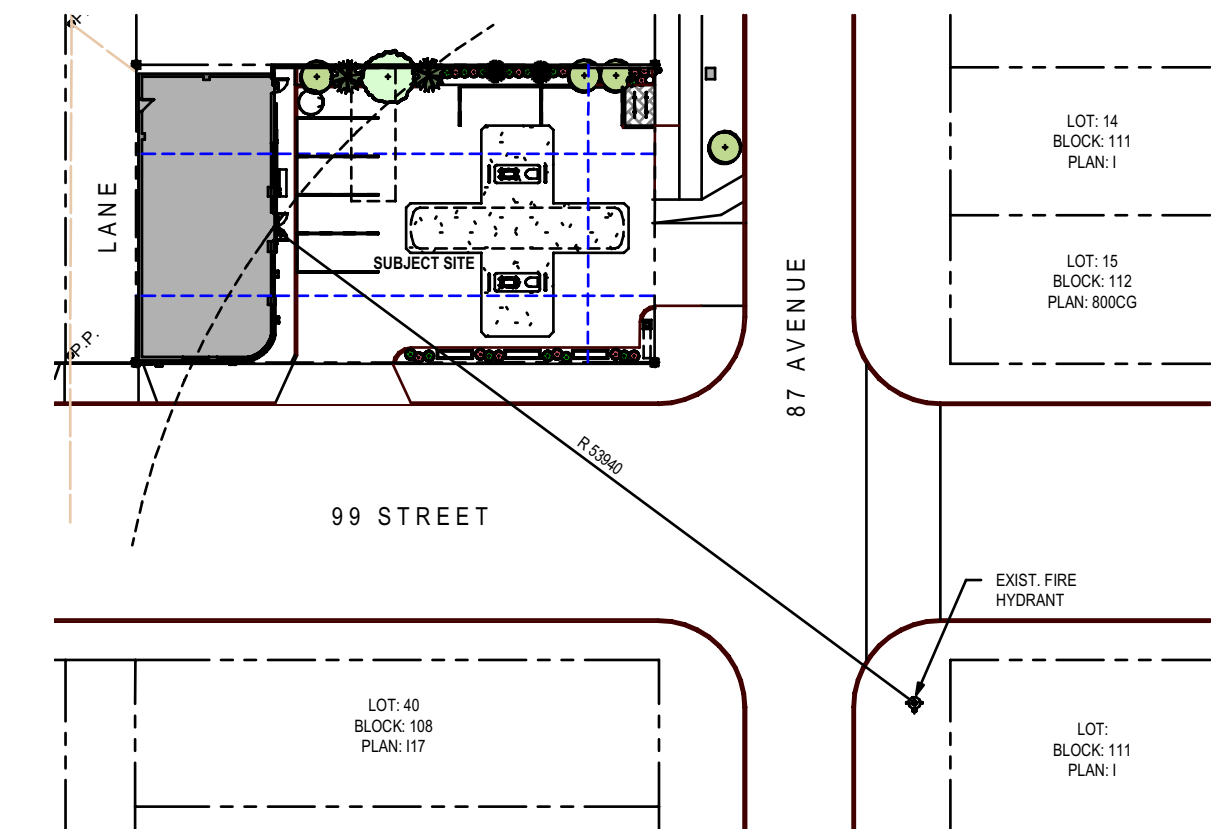
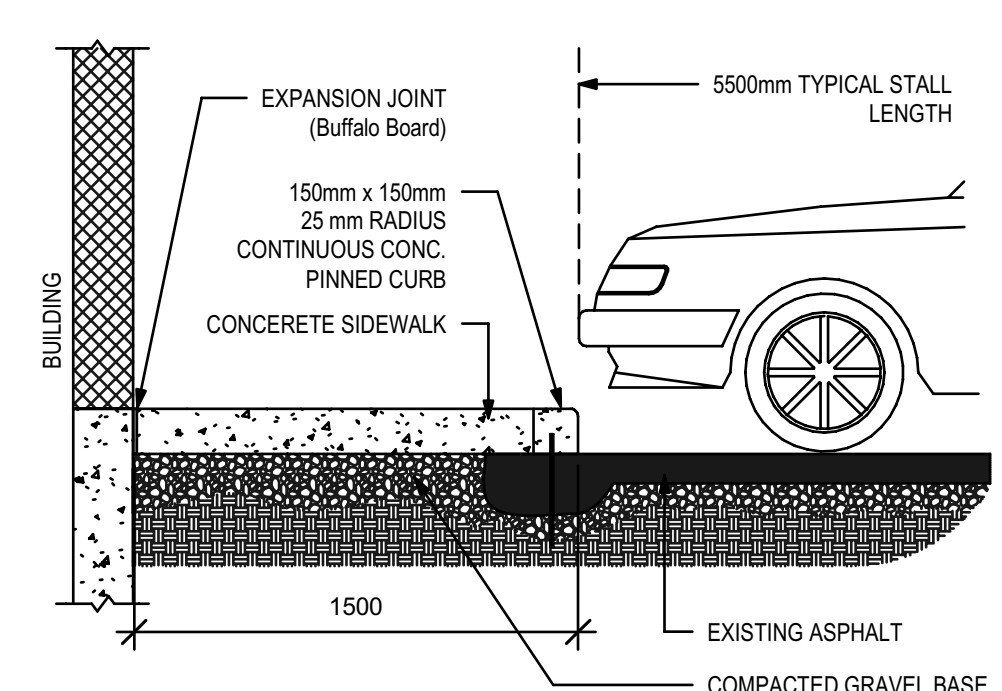
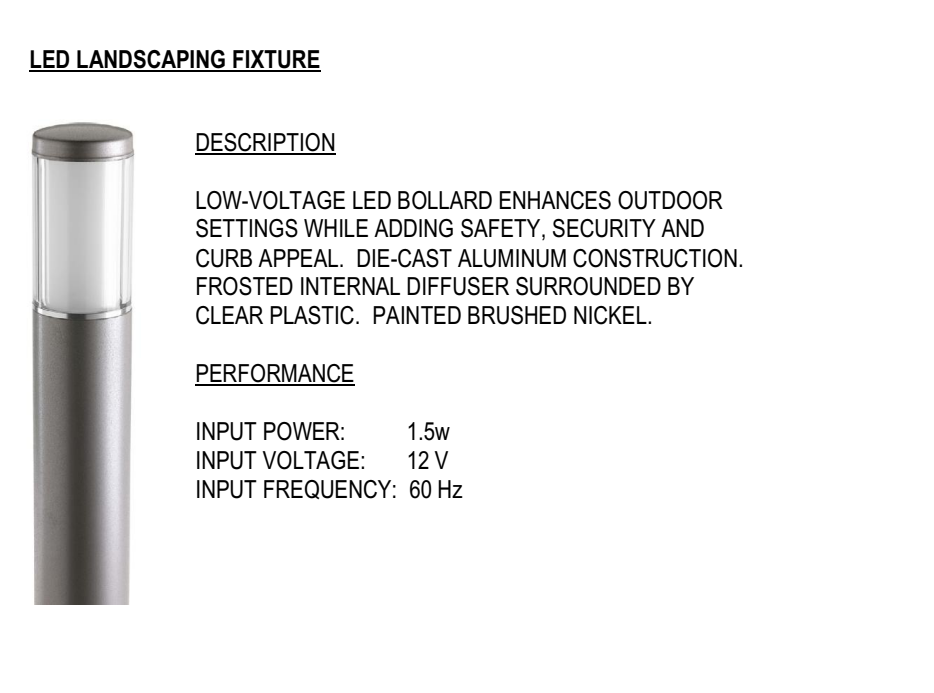

4 MOLOK GARBAGE SECTION
DP1.0 1 : 15

3 SIDEWALK DETAIL
DP1.0 1 : 25

2 KEY PLAN
DP1.0 1 : 500